

RANS

4600 Highway 183 Alternate
Hays, KS 67601
(785) 625-6346
Fax (785) 625-2795
www.rans.com

Airworthiness Directive: 136

Date: May 14, 2010

Subject: Hour meter oil pressure switch leak

Compliance: Mandatory

Models Affected: All RANS aircraft with ROTAX 912 engines equipped with an oil pressure switch for hour meter

It has been brought to our attention that failures have occurred in the internal seal of the Oil Pressure Switch (RANS P/N KSES0004). This has caused premature loss of oil resulting in engine failure.

Please follow the instructions provided to insure your safety in this matter.

Compliance:

Inspect for leaks before next flight. If leaks or defects are found, remove the aircraft from service until it is possible to replace the oil pressure switch with a 1/8" pipe plug and install Hour Meter Relay Assembly.

Continued Airworthiness:

Option 1 - Inspect at every flight and at condition inspection. Replace with 1/8" pipe plug and install Hour Meter Relay Assembly (RANS P/N KAES0016) if leaks or defects are found.

Option 2 - Replace oil pressure switch with 1/8" pipe plug and Hour Meter Relay Assembly (RANS P/N KAES0016).
Contact RANS Parts Department for Hour Meter Relay Assembly and Plug Kit.

Inspection Location:

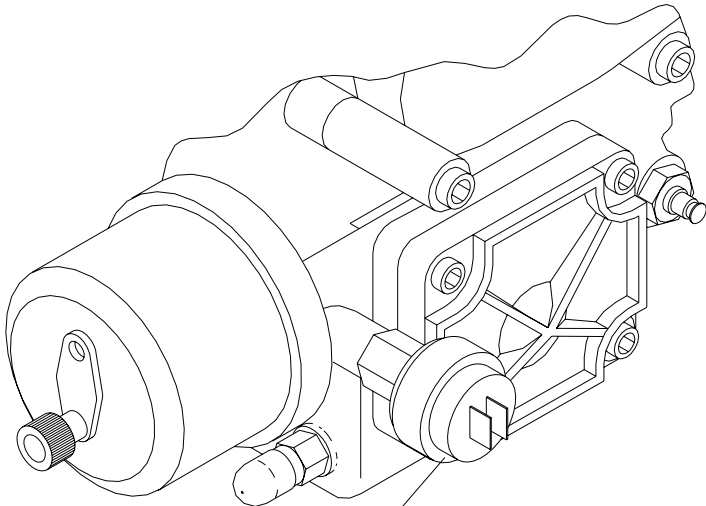

MD5506

INSPECT FOR OIL LEAK HERE

Oil Switch Removal:

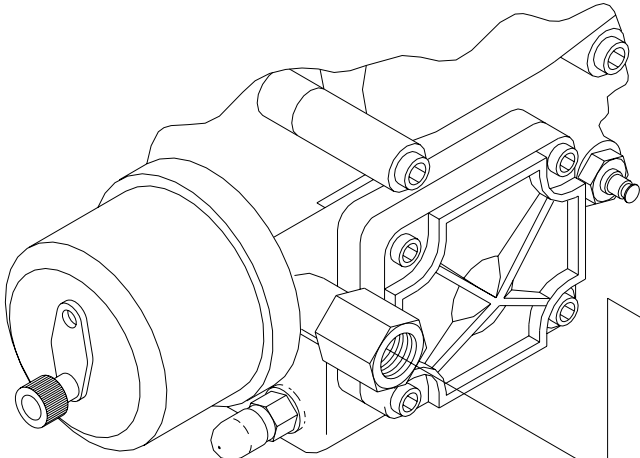

REPLACE WITH PLUG*

*USE TEFLON TAPE WHEN INSTALLING PLUG

REMOVE OIL SWITCH

MD5506

Thank you for your attention to this matter. Hopefully, we have not inconvenienced you to any great degree.

Fly safe.