

AIRWORTHINESS DIRECTIVE: 051592-01 (102)

SUBJECT: 116 WING JURY STRUTS

COMPLIANCE: MANDATORY

COST: ONLY YOUR TIME TO INSTALL

MODELS EFFECTED: S-6ES 116 WING

It has been determined that jury struts are now required on the S-6ES 116 wing. This is due to higher cruise speeds, increased gross weights, and rear strut vibration. A quick folding feature has been incorporated into the struts. Set-up and knock down time should only take a few seconds more. With the jury struts a gross weight of 1,100 pounds is now possible.

FIELD JURY STRUT INSTALLATION

1. Collect the parts called out in the parts list for the jury strut. It is assumed the aircraft is assembled with the wings and struts on.
2. Cut the tubing provided for the jury struts to the lengths designated in figure 0022E-02. De-burr the ends.

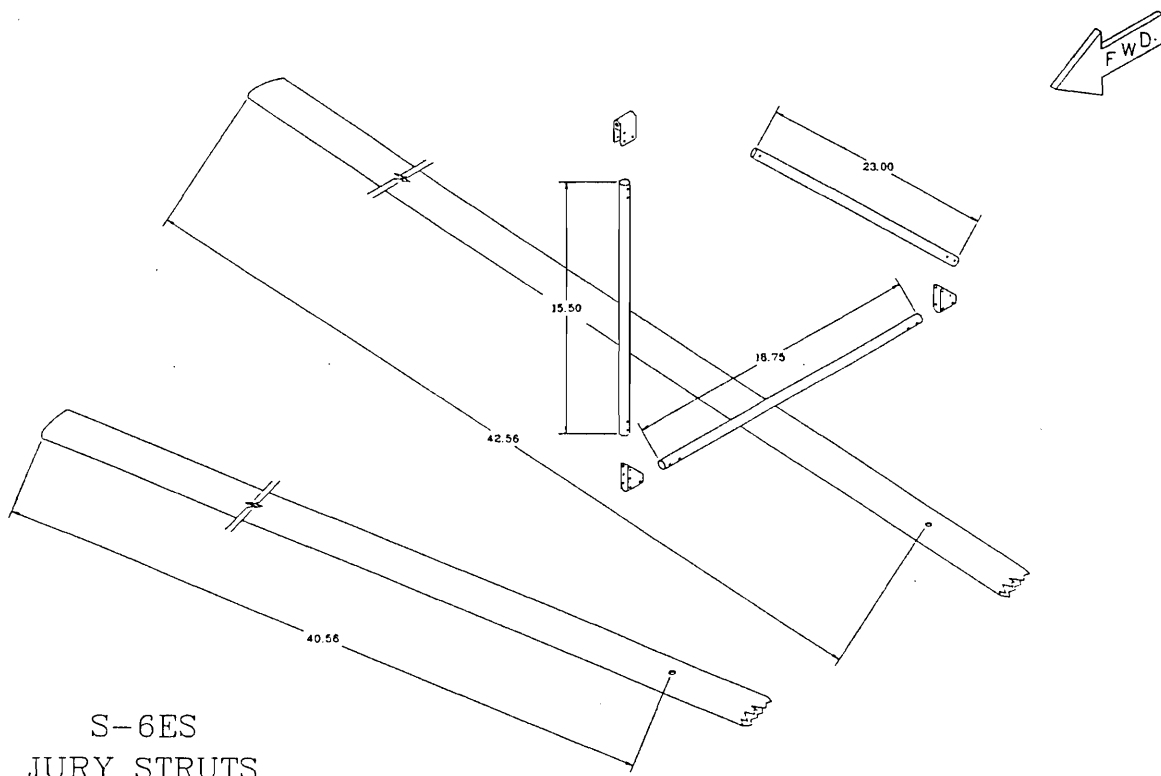
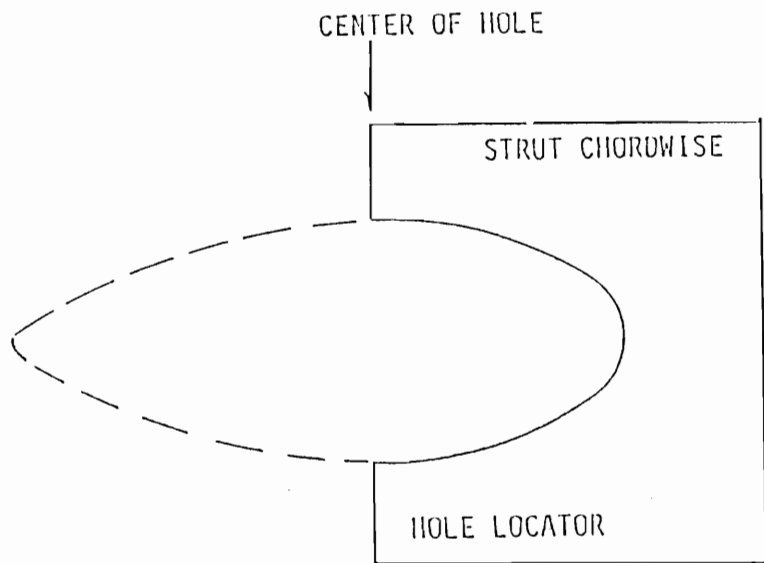

Figure 0022E-02

3. Drill out the holes to #30 as shown in figure 0022E-04.

4. Measuring from the top end of the lift struts, mark and drill a 1/4" hole for the eye bolts. See figure 0022E-02 for locations. See figure 0022E-03 for a template. Bolt the eyebolts to the struts with the flanges 90 degrees to aircraft centerline. Be careful not to overtighten.



To Use:
Cut out and
place over strut
mark where template
ends.

Figure 0022E-03

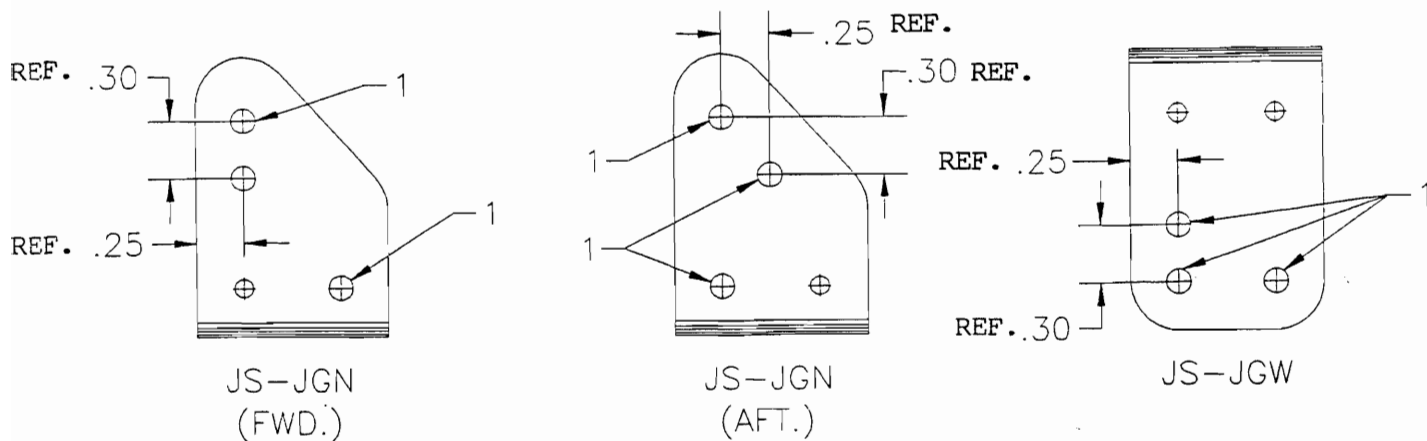

1. DRILL HOLES TO #30

Figure 0022E-04

5. Insert the PVC bushing into the ends of the two crossing tubes. Retain the bushings by making a slight dimple on the tube with a punch.

6. The gussets will need to line up with each other on the crossing tubes. Lay the assembly on a flat table. Extend the ends of the tubes $1/8$ " from the gussets. See figure 0022E-06. Rivet the gussets to the tube via the #30 holes using #30 stainless steel pop rivets.

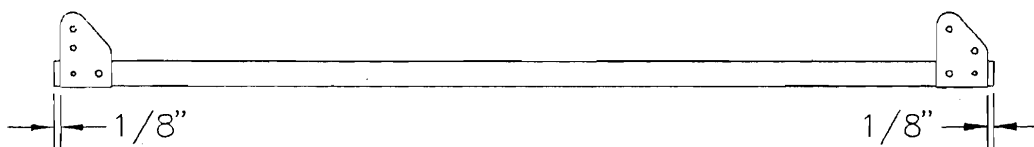
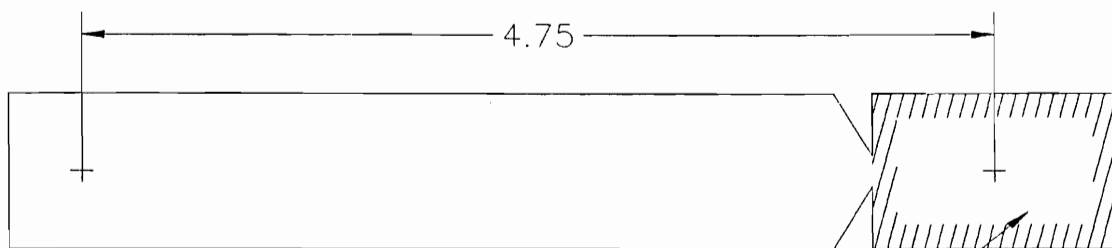
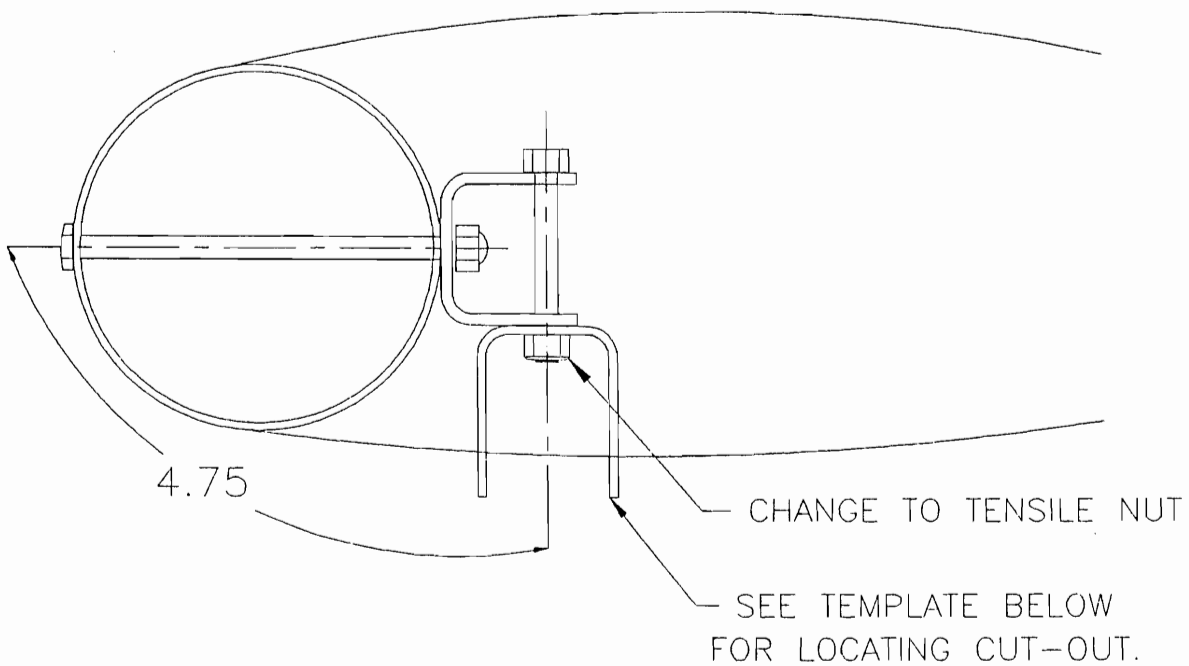

Figure 0022E-06

7. Cotter pins are to be used to retain the clevis pins to the crossing tube via the smaller undrilled holes in the gussets. Drill through the bushing insert with a #40 bit.

8. Install the top jury strut bracket, do this by locating the bolt above the jury strut cross tube. This bolt head protrudes from the leading edge of the forward spar directly above the cross over tube and retains the inboard long wing channel. If you have already installed the skin to your wings use the JS-BK template to hot knife a hole just big enough for it to fit. To reach the top of the bolt we have used a open end wrench taped to a wood dowel. Use the inboard $3/16$ " AN3-15A bolt to attach the JS-BK to the channel also. Because of the tensile load on the jury strut, you must use a tensile nut instead of a shear nut. (figure 0022E-07) Place the top jury strut gusset in the bracket. Use the quick pin to retain the JS-JGW to JS-BK. Insert the jury strut tubes into the gussets. Align, drill, and rivet. NOTE: You may have to trim part of the jury strut ends for clearance.

9. To fold: remove the quick pin and fold toward tip.



JS-BK TEMPLATE —
DRAW AROUND THIS AREA AND
CUT OUT WITH HOT KNIFE FOR
BRACKET HOLE THROUGH SKIN.

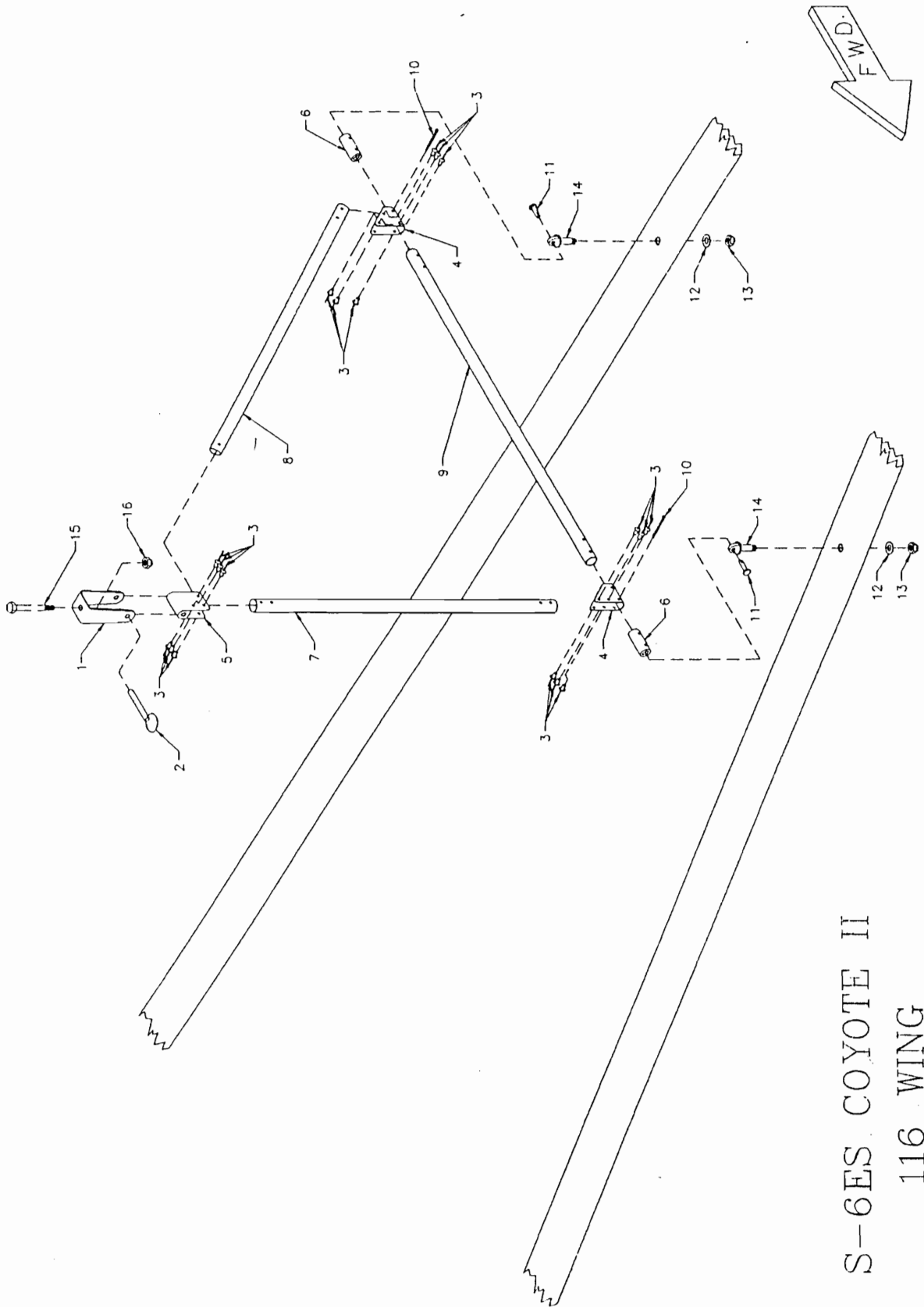

S-6ES COYOTE II
116 WING
JURY STRUTS

S-6 116 JURY STRUT

#	PART NAME	PART NO.	QTY.	PRICE
1.	Jury Strut Bracket	JS-BK	2	1.36
2.	Retaining Pin	3/16x1.2 SSBP	2	3.86
3.	1/8"stainless Steel Pop Rivet.		36	.36
4.	Notched Gusset	JS-JGN	4	.80
5.	Welded Gusset	JS-JGW	2	.80
6.	Drilled Bushing PVC Insert	JS-BUC-B	4	3.00
7.	Forward Jury Strut*	JS-FWD-15	2	{5.40}*
8.	Diagonal Jury Strut*	JS-DIA-23	2	{5.40}*
9.	Cross Jury Strut*	JS-C-18	2	{5.40}*
10.	Small Cotter Pin	AN380-3	4	.10
11.	Clevis Pin	RL-13/MS20392-2017	4	.50
12.	1/4 Thin Washer	AN960-416	4	.26
13.	1/4 Acorn Nut	42NKE048	4	.50
14.	Eye Bolt	AN43B-15A	4	3.30
15.	3/16" Bolt	AN316A	2	.28
16.	3/16" Tensil Nut	AN365-1032	2	1.20

*Builder must fabricate these from 1/2"x.035x144 stock provided.