



Airworthiness Directive: #110

Date: June 6, 1996

Subject: S-4/5 Rudder Spar

Compliance: Mandatory

Models Effected: S-4/5 Coyote

Cost: Materials - no charge. Your time and labor are the only cost

It has been determined that the rudder spar supplied with your S-4/5 kit may be missing a .875 x .058 x 18.00" doubler. Please inspect your rudder L.E. spar; if this doubler is not in place, contact our parts department so that a doubler can be shipped to you at no cost. See the figure below for location of the doubler.

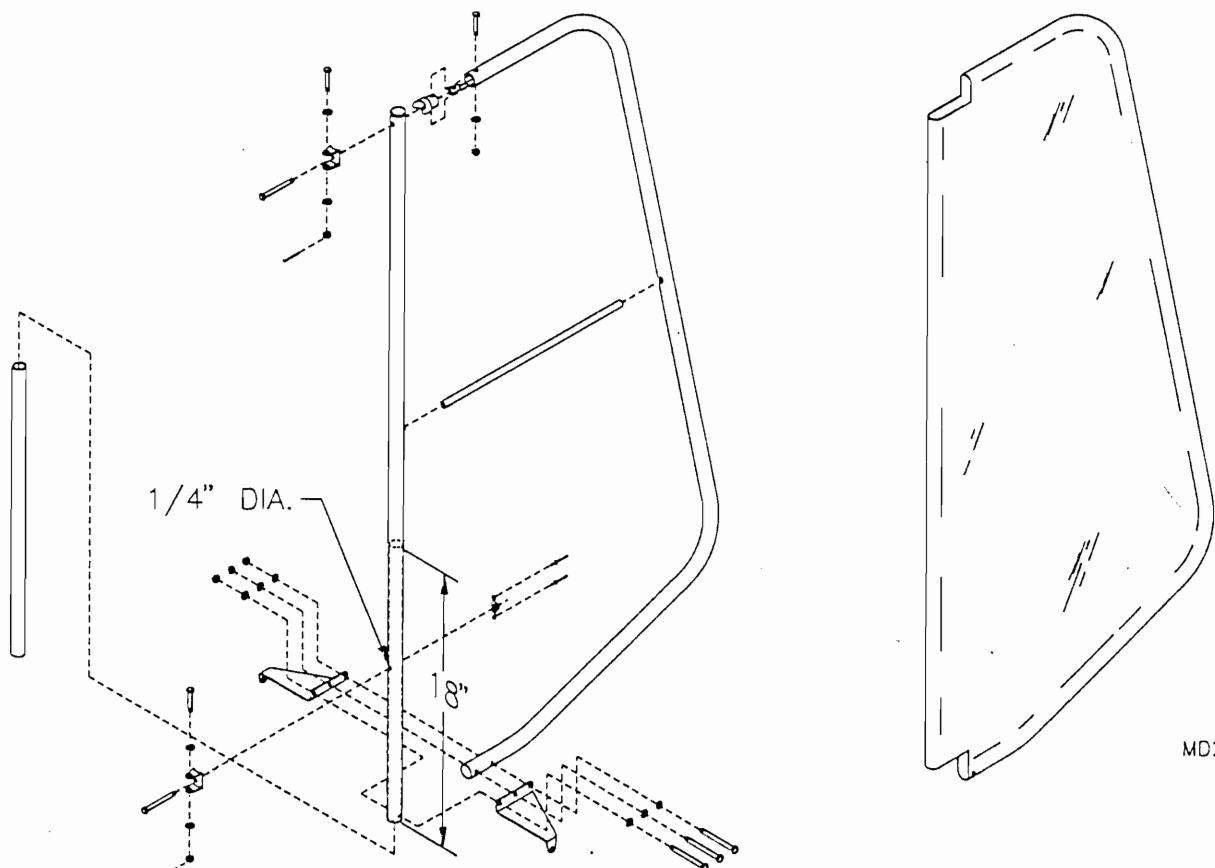

MD2506

Doubler Installation Instructions (see figure previous page):

1. Remove rudder skin (if installed).
2. Remove 1/4" nut plate and forward bolt in the rudder horn assembly.
3. Install 18" doubler in the lower end of the L.E. spar so that it is flush with the bottom of the tube. Using the hinge holes in the L.E. spar, drill the doubler out to 1/4" to allow for the hinge bolt.
4. Reinstall 1/4" nut plate using 40APR1/4 rivets supplied with the doubler. Reinstall the forward bolt in the rudder horn assembly. The #40 rivets and the 1/4" bolt will hold the doubler in place.
5. Re-skin rudder according to the manual instructions.