

S-21 OUTBOUND

AIRCRAFT SPECS AND PERFORMANCE

All metal, all purpose.

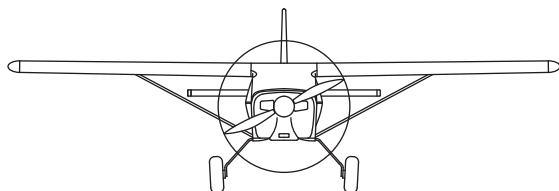
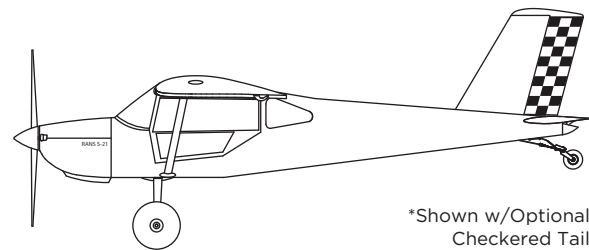
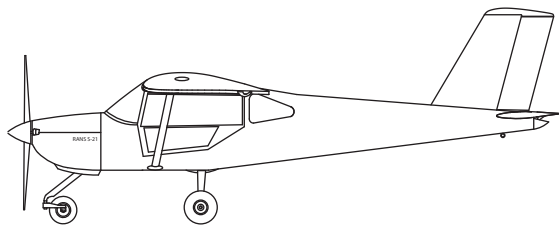
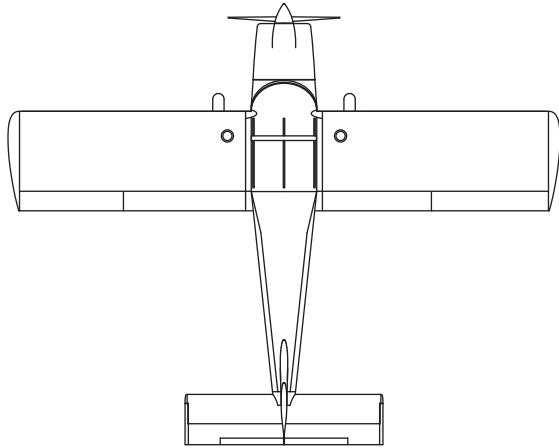

SPECIFICATIONS	ROTAX 915 IS	TITAN x-340
Wing Span	28 ft.	28 ft.
Wing Area	141 sq. ft.	141 sq. ft.
Length	22.41 ft.	22.41 ft.
Height Tailwheel	78"	78"
Height Trike	102.65"	102.65"
Cockpit Width	46.5 in.	46.5 in.
Landing Gear	F/TDTK	F/TDTK
Baggage Volume	24 cu. ft.	24 cu. ft.
Baggage Capacity	120 lbs.	180 lbs.
Fuel Capacity	44.9 gal.	44.9 gal.

POWER PLANT	ROTAX 915 IS	TITAN x-340
Output	141 hp	180 hp
Propeller Diameter	72 in.	80 in.
WhirlWind	Gr. Adj.	Gr. Adj.
AirMaster	Electric	N/A

WEIGHTS & LOADINGS	ROTAX 915 IS	TITAN x-340
Gross Weight EAB	1,800 lbs.	1,800 lbs.
Gross Weight SLSA	1,320 lbs.	1,320 lbs.
Empty Weight	915 lbs.	1,000 lbs.
Useful Load EAB	885 lbs.	800 lbs.
Useful Load SLSA	405 lbs.	320 lbs.
Limit Loading	+6 /-2	+6 /-2

PERFORMANCE	ROTAX 915 IS	TITAN x-340
Take Off Roll	315 ft.	325 ft.
Service Ceiling	18,000 ft.	14,000 ft.
Vc	145 mph TAS	155 mph TAS
Vne	215 mph	215 mph
Stall Clean	50 mph	50 mph
Stall Flaps	40 mph	45 mph
Landing Roll	375 ft.	375 ft.
Endurance**	5 hrs.	5 hrs.

** Plus .5 hr. reserve