

S-21 OUTBOUND

TITAN IOX-340 SPECS AND PERFORMANCE

All metal, all purpose.

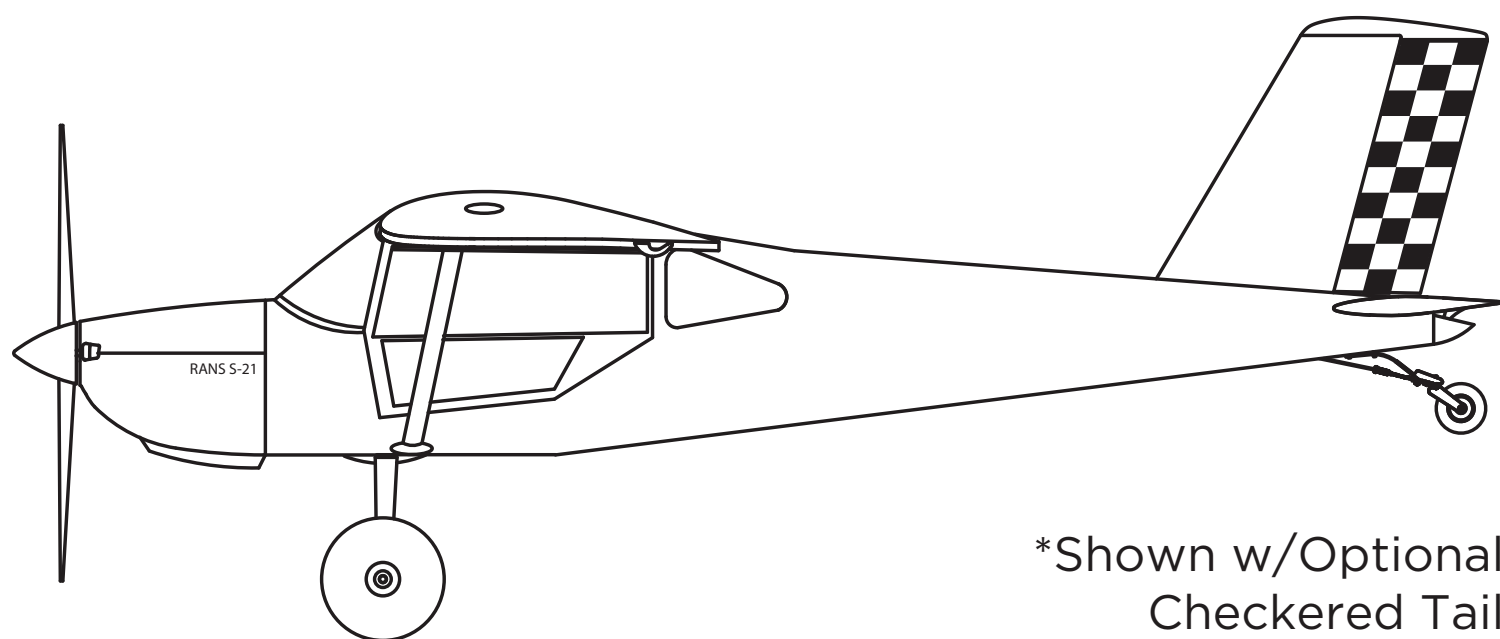
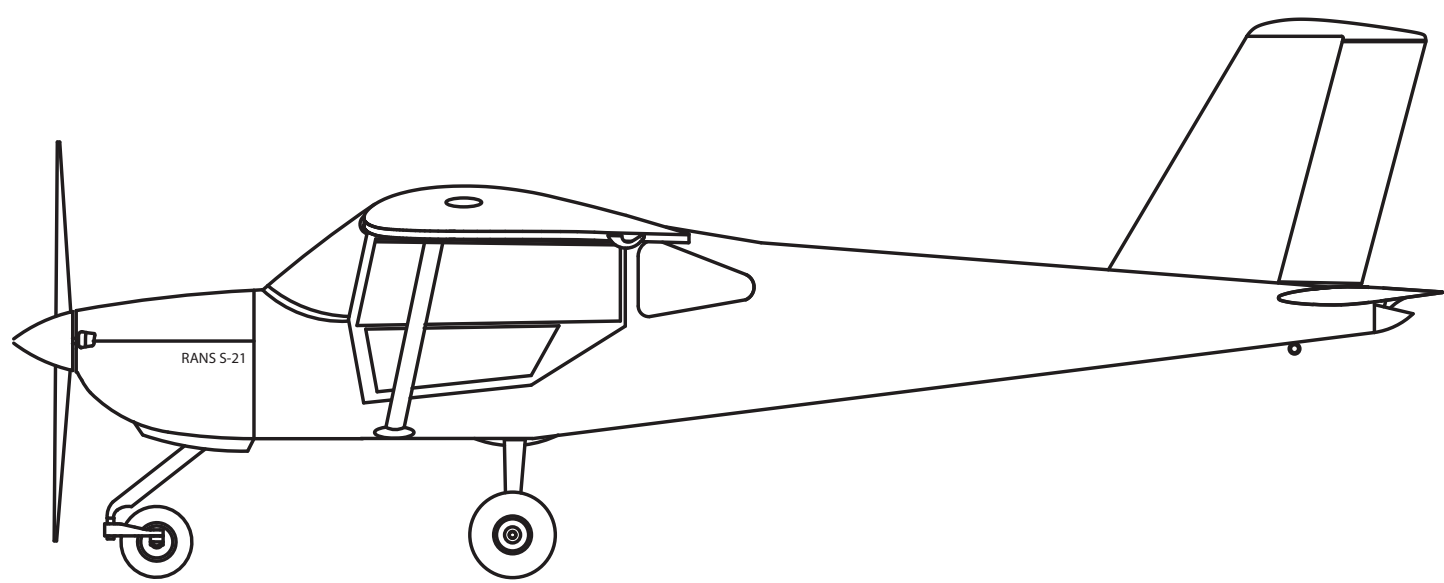
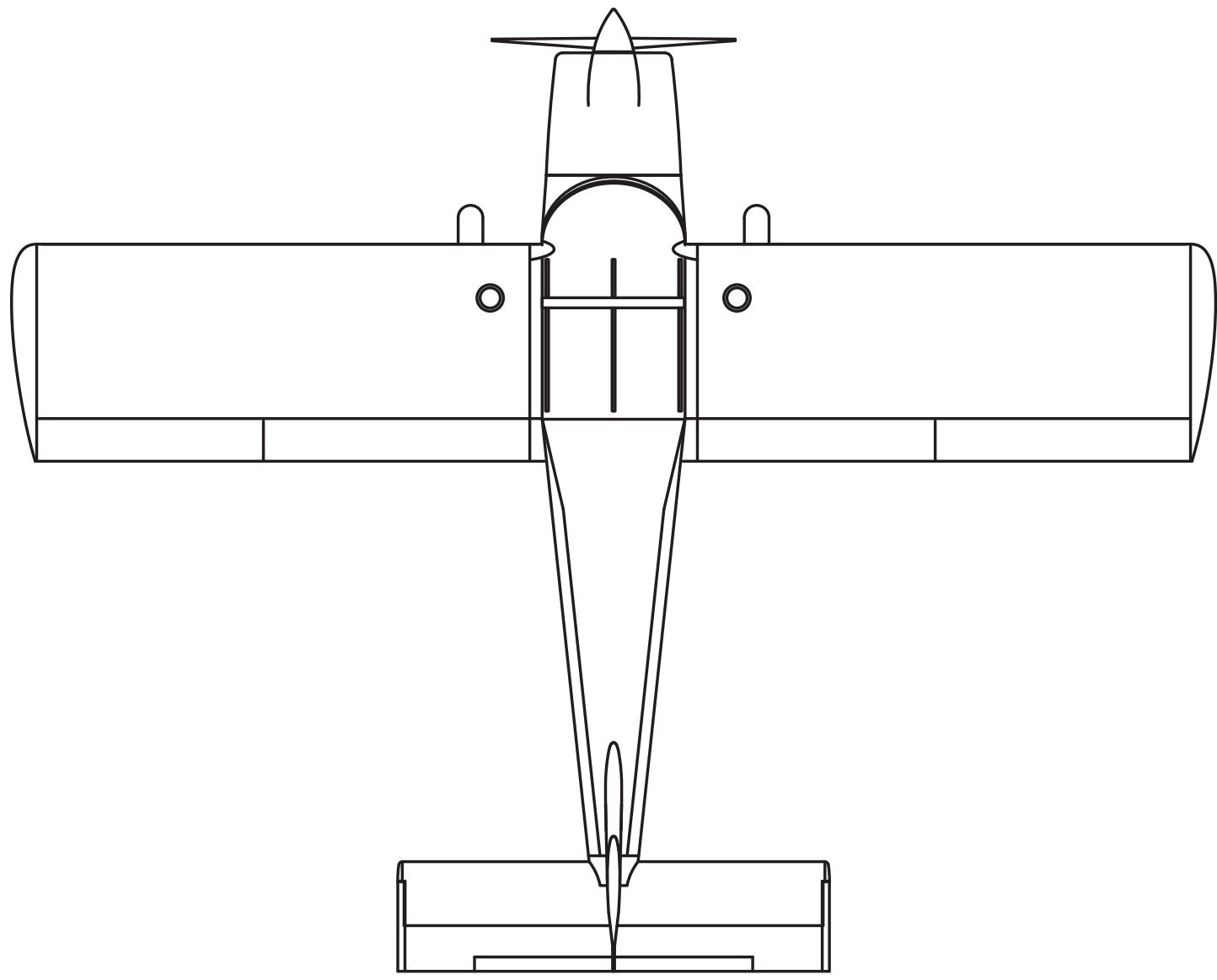

*Shown w/Optional
Checked Tail

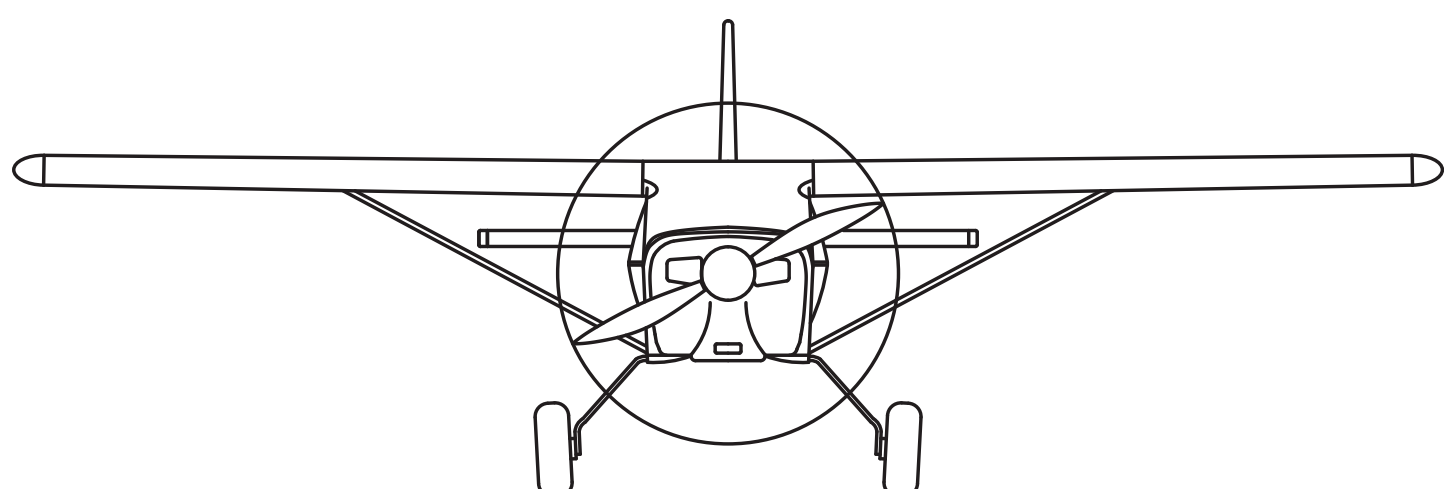

SPECIFICATIONS

180 HP	
Fuel Injected	
Dual LightSpeed Electronic Ignition	
Dynafoal 1 Mount	
9.0:1 Compression	
Roller Lifters	
Lightweight Sky-Tec Starter	
Plane Power 60AMP Alternator	
14MM Spark Plugs	
Baggage Capacity	180 lbs
Fuel	100LL
Fuel Capacity	44.9 gal

PROPELLER

Propeller Diameter	80 in
WhirlWind	Gr. Adj.

WEIGHTS & LOADINGS

Gross Weight EAB	1800 lbs.
Gross Weight SLSA	1320 lbs.
Empty Weight	1000 lbs.
Useful Load EAB	800 lbs.
Useful Load SLSA	320 lbs.

PERFORMANCE

Take Off Roll	325 ft
Service Ceiling	14,000 ft
Vc	155 mph TAS
Vne	215 mph
Stall Clean	50 mph
Stall Flaps	45 mph
Endurance**	5 hrs

** Plus .5 hr. reserve